

Features and Benefits

- Full Redundant Sensor
- Analog Signal Processing
- Quad Switched Hall Plate
- Chopper Stabilized Amplifier
- Linear Analog Ratiometric Output Voltage
- Programmable Output Quiescent Voltage (V_{OQ})
-100% V_{DD} ...200% V_{DD} Range
- Programmable Magnetic Sensitivity
- Programmable Low Pass Filter
- Programmable Clamping Voltage
- Programmable Temperature Compensation
- Melexis ID Number
- Programmable Customer ID Number
- Lead-free package

Application Examples

- Linear Position Sensing
- Rotary Position Sensing
- Current Sensing
- Magnetic Field Measurement

Ordering Information

Part No.	Temperature Code	Package Code	Option Code SR(IC_A, IC_B) [†]
MLX90277	E (-40°C to 85°C)	GO (TSSOP 14)	SRA-B, (A = 0, 1, 2, or 3) (B = 0, 1, 2, or 3)

Example: MLX90277EGO SR2-1

[†]Please see section 10.4 for detailed information on the option codes.

1 Functional Diagram

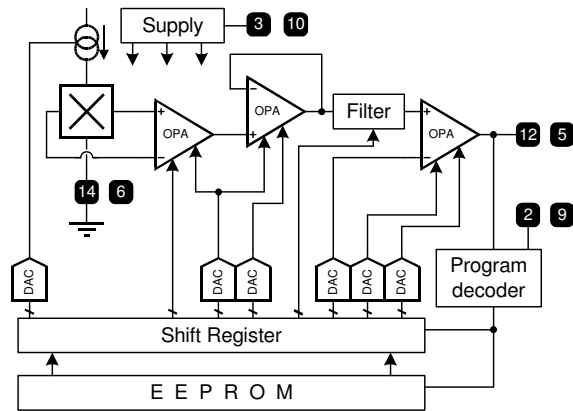

Figure 1-1 Functional Diagram

	TSSOP 14 pin out	
	IC_A	IC_B
Vdd	3	10
Out	12	5
Vss (Ground)	14	6
Test	2	9
NC	1 - 4 - 7 - 8 - 11 - 13	

Table 1: Pin out

2 General Description

The MLX90277 is a Dual Programmable Ratiometric Linear Hall Effect sensor. Two discrete CMOS ICs are mounted inside a single package, electrically insulated, and independently programmable. The MLX90277 is suitable for applications requiring full redundancy. The linear output voltages are proportional to the magnetic flux density. The ratiometric output voltages are proportional to the supply voltages. The MLX90277 possesses active error correction circuitry, which virtually eliminates the offset errors normally associated with analog Hall Effect devices. All the parameters of the MLX90277 transfer characteristic are fully programmable. The V_{OQ} ($V_{OUT} @ B = 0$ Gauss), the Sensitivity, the slope polarity, the Output Clamping levels, the thermal Sensitivity drift, the internal bias point and a low-pass filter are all programmable in end-user applications. The MLX90277 has a very stable thermal compensation for both the Sensitivity and the V_{OQ} over a broad temperature range. For traceability purpose the MLX90277 will carry a unique ID number programmed by Melexis and 24 bits of EEPROM memory are allocated for a user programmed serial number.

Table of Contents

1 Functional Diagram	1
2 General Description	1
3 Glossary of Terms	3
4 Maximum Ratings	3
5 Detailed Block Diagram	4
5.1 Detailed Description	4
6 General Electrical Specifications	5
7 Programming Range	6
8 Timing Specifications	6
9 Accuracy	6
10 Programmable Features	7
10.1 Output Quiescent Voltage (V_{OQ})	8
10.2 Thermal V_{OQ} Drift (DRIFT)	8
10.3 Sensitivity, Rough Gain and Fine Gain	8
10.4 Sensitivity Range Selection	9
10.5 Sensitivity Polarity (INVERT)	11
10.6 Clamping Levels (CLAMPLOW, CLAMPHIGH)	11
10.7 Filter (FILTER)	12
10.8 Sensitivity Temperature Compensation (TC, TCW, TC^2)	12
10.9 Diagnostic Output Level (FAULTLEV)	13
10.10 The EEPROM, Parity and Melexis CRC	13
10.11 Output Amplifier Configuration (MODE)	14
10.12 Memory Lock (MEMLOCK)	14
10.13 IC traceability	14
11 Performance Graphs	14
12 Applications Information	15
12.1 Application Circuits	15
12.2 Programming the Sensor	16
12.3 Calibration Procedure	17
13 Standard information regarding manufacturability of Melexis products with different soldering processes	18
14 ESD Precautions	18
15 Package Information	19
15.1 Package Dimensions	19
15.2 Pin-out and Marking	20
15.3 Hall Plate Positioning	20
16 Disclaimer	21

Note: All specifications apply to IC_A and IC_B unless otherwise noted.

3 Glossary of Terms

- mT (milli-Tesla) = Unit of measurement for magnetic flux density. 1 mT is equal to 10 Gauss.
- V_{OQ} (Output Quiescent Voltage) = Output voltage at zero magnetic field, V_{OUT} for $B = 0$ mT.
- Sensitivity = Change in output voltage versus change in magnetic field, $\Delta V_{OUT} / \Delta B$.
- TempCo (Sensitivity Temperature Compensation) = Change in Sensitivity over temperature. Listed in units of ppm / °C (100ppm / °C. = 0.01 % / °C.).
- PTC (Programming Through the Connector) = Melexis in circuit programming protocol.
- MSB = Most Significant Bit.
- LSB = Least Significant Bit.

4 Maximum Ratings

Parameter	Units
Maximum Supply Voltage, V_{DD_MAX} (Over Voltage)	30 V
Maximum Supply Current, I_{DD_MAX} (Over Voltage)	50 mA
Reverse Voltage, V_{DD_REV}	- 15 V
Reverse Supply Current, I_{DD_REV}	- 85 mA
Positive Output Voltage, V_{OUT_MAX}	24 V
Positive Output Current, $I_{OUT_POS_FAULT}$	40 mA
Reverse Output Voltage, V_{OUT_REV}	- 0.7 V
Reverse Output Current, $I_{OUT_REV_FAULT}$	-50 mA
Operating Ambient Temperature Range, T_A	-40°C to 150°C
Storage Temperature Range, T_S	-55°C to 165°C
Magnetic Flux Density	Infinite

Table 2: Absolute Maximum Ratings

Note: Exceeding the absolute maximum ratings may cause permanent damage. Exposure to absolute-maximum-rated conditions for extended periods may affect device reliability.

5 Detailed Block Diagram

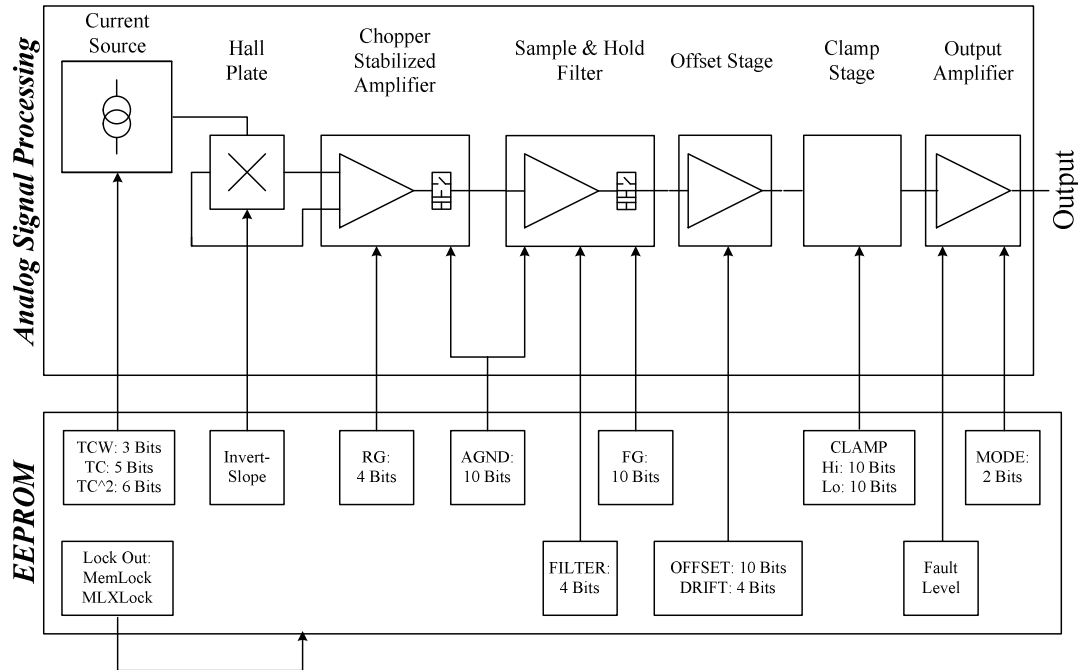

Figure 5-1 Detailed Block Diagram

5.1 Detailed Description

Integrated on each individual IC within the MLX90277 is a temperature-compensated quad switched Hall plate, chopper stabilized amplifiers, adjustable output filter, output driver, voltage protection circuitry and a programmable EEPROM with security and redundancy. Programming the EEPROM allows each device to be calibrated in the application.

In normal operation data stored in the EEPROM feeds a register, RAM, that updates internal DACs and switches that effect the operation of the device. In programming mode the RAM can be directly accessed to allow faster calibration of the parameters. Communication to the device is done using Melexis' PTC serial interface.

6 General Electrical Specifications

DC operating parameters at $V_{DD} = 5V$ (unless otherwise specified) and for T_A as specified by the temperature range (E).

Parameter	Symbol	Test Conditions	Min	Typical	Max	Units
Nominal Supply Voltage	V_{DDNOM}		-	5	-	V
Operating Supply Voltage	V_{DD}^\dagger		4.5	-	5.5	V
Nominal Supply Current	I_{DDNOM}	$V_{DD} = V_{DDNOM}$	4.0	7.0	8.0	mA
Supply Current	I_{DD}	$V_{DD} = 4.5 \dots 5.5 V$	3.0	-	9.0	mA
Output Voltage Swing	V_{OUTPD}	Pull Down Load $\geq 10 k\Omega$ no clamping	2		96	% V_{DD}
	V_{OUTPU}	Pull Up Load $\geq 10 k\Omega$ no clamping	5		97	% V_{DD}
Output Current	I_{OUT}	$V_{DD} = V_{DDNOM}$	-1.25		1.25	mA
Output Short-Circuit Current	I_{OUTSC+}	$V_{DD} = V_{DDNOM}$ Output shorted to supply-permanent	-12		-4	mA
	I_{OUTSC-}	$V_{DD} = V_{DDNOM}$ Output shorted to ground-permanent	4		12	mA
Diagnostic Output Voltage	V_{OUT1}	Broken supply, Pull-down load $> 10 k\Omega$	0		0.5	% V_{DD}
	V_{OUT2}	Broken ground, Pull-down load $> 10 k\Omega$	94	96	100	% V_{DD}
	V_{OUT3}	Broken supply, Pull-up load $> 10 k\Omega$	0	3	5	% V_{DD}
	V_{OUT4}	Broken ground, Pull-up load $> 10 k\Omega$	99.5		100	% V_{DD}
Power on Reset	V_{DD_POR}	Voltage on V_{DD}	1.5		3.8	V
Over Voltage Detection	V_{DD_OVD}	Voltage on V_{DD}	6.5		8.5	V
Substrate Insulation	R_{DIES}	200VDC across V_{SS1} and V_{SS2}	0		50	μA

Table 3: Electrical Specifications

[†] The ratiometric output voltage is proportional to the supply voltage. When using the supply voltage as a reference for an A/D converter, fluctuations of $\pm 10\%$ in supply voltage are compensated.

7 Programming Range

T_A programming 20 °C to 30 °C.

Parameter	Symbol	Test Conditions	Min	Typical	Max	Units
Output Quiescent Voltage	V _{OQ}	AGND = Default	-10		110	%V _{DD}
		AGND = 0...1023	-100		200	%V _{DD}
Sensitivity	S		2.6		210	mV/mT
Output Clamping Voltage Low	ClampLo		0		100	%V _{DD}
Output Clamping Voltage High	ClampHi		0		100	%V _{DD}
Temperature Compensation	TempCo	1 st order	0		2300	ppm / °C

Table 4: Programming Range Specifications

8 Timing Specifications

DC operating parameters at V_{DD} = 5V (unless otherwise specified) and for T_A as specified by the temperature range (E).

Parameter	Symbol	Test Conditions	Min	Typical	Max	Units
Power On Delay	T _{PO}	FILTER = 0, RG = 0		0.4	0.8	ms
		FILTER = 0, RG = 15		0.6	1.2	ms
		FILTER = 15, RG = 0		1.1	2.2	ms
		FILTER = 15, RG = 15		5	10	ms
Step Response Time		RG = 0 to 3, FILTER = 0	24		32	µs
		RG = 4 to 7, FILTER = 0	48		64	µs
		RG = 8 to 11, FILTER = 0	100		132	µs
		RG = 12 to 15, FILTER = 0	200		264	µs

Table 5: Timing Specifications

9 Accuracy

DC operating parameters at V_{DD} = 5V (unless otherwise specified) and for T_A as specified by the temperature range (E).

Parameter	Symbol ^{††}	Test Conditions	Min	Typical	Max	Units
Thermal Voq Drift	Δ ^T V _{OQ}	V _{OQ} = 2.5V ⁽¹⁾ , 25 °C / 150 °C V _{OQ} = 2.5V ⁽¹⁾ , 25 °C / -40 °C	- 0.2 - 0.4		+ 0.2 + 0.4	%V _{DD} %V _{DD}
Life Time Drift of the Thermal Voq Drift	Δ ^L Δ ^T V _{OQ}		- 0.2		+ 0.2	%V _{DD}
Life Time Voq Drift	Δ ^L V _{OQ}		- 0.3		+ 0.3	%V _{DD}
Life Time Sensitivity Drift	Δ ^L S		- 1		+ 1	%
Sensitivity Temperature Coefficient [†]	TCs	0 to 500 ppm / °C			± 100	ppm / °C
		500 to 1200 ppm / °C			± 150	ppm / °C
		1200 to 2300 ppm / °C			± 200	ppm / °C
Thermal Drift of Sensitivity Temperature Compensation	Δ ^T TC				150	ppm / °C
Thermal Drift Output Clamping Levels	Δ ^T V _{OUTCLAMP}		- 0.4		+ 0.4	%V _{DD}
Life Time Drift Output Clamping Levels	Δ ^L V _{OUTCLAMP}		- 0.2		+ 0.2	%V _{DD}
Linearity error	Le			0.2		%

Table 6: Accuracy Specifications

† Valid for Rough Gain within the specified option code.

†† Δ^L = Life Time Drift (based on HTOL data [1000 hours @ 150°C]).

Δ^T = Thermal Drift.

(1) For other test conditions, please contact the Melexis Sales representative of your area.

10 Programmable Features

The MLX90277 has many programmable features for adjusting the output characteristics. The parameters are independently programmable for IC A and IC B. The features are utilized by writing data into the redundant non-volatile EEPROM. Below is a quick list and description of all the programmable parameters. Many of the parameters are set by Melexis and they are not used by the end customer. Later sections of the data sheet give details on how the parameters are used.

Parameter	Symbol	Description	Number of Bits	Default IC_A	Default IC_B
Internal Bias Point	AGND	Coarse adjustment of V_{00} .	10	Trimmed	Trimmed
Analog Clock Choice†	CKANACH	Adjustment for amplifier clock generator.	2	Preset	Preset
Clamping High	CLAMPHIGH	Adjustment of upper output clamping voltage.	10	768	256
Clamping Low	CLAMPLOW	Adjustment of lower output clamping voltage.	10	768	256
Customer ID††	CUSTID	Open bits for customer programming.	24	Preset	Preset
Offset Drift†	DRIFT	V_{00} temperature drift compensation.	4	Trimmed	Trimmed
EEPROM Fault Level	FAULTLEV	Output state for EEPROM parity error.	1	0	0
Fine Gain	FG	Fine adjustment for Sensitivity.	10	0	0
Filter	FILTER	Adjustment for low pass output filter.	4	0	0
Invert Slope	INVERT	Sensitivity polarity selection.	1	0	0
Memory Lock	MEM_LOCK	Used to lock the entire EEPROM.	1	0	0
Melexis ID†	MLX_ID	Melexis IC identification number.		Preset	Preset
Melexis Lock†	MLX_LOCK	Used to lock Melexis area of the EEPROM.	1	0	0
Output Driver†	MODE	Adjustment for output stage amplifier.	2	1	1
Offset DAC	OFFSET	Fine adjustment of V_{00} .	10	0	0
Oscillator Adjust†	OSCADJ	Chip oscillator frequency adjustment.	4	Preset	Preset
EEPROM Parity	PARITY	Ensures the integrity of the EEPROM data.	3	Calculated	Calculated
Rough Gain	RG	Rough adjustment for Sensitivity.	4	0	0
Slow†	SLOW	Amplifier speed adjustment.	1	Preset	Preset
Temperature Compensation Window	TCW	Range adjustment for Sensitivity Temperature Compensation.	3	0	0
Temperature Compensation	TC	Fine adjustment of Sensitivity Temperature Compensation.	5	0	0
2nd Order Temperature Compensations	TC ²	Linearization adjustment of the Sensitivity Temperature Compensation.	6	0	0

Table 7: Programmable Parameters

† Melexis parameter adjusted at final test.

†† Not included in redundant area of the EEPROM.

10.1 Output Quiescent Voltage (V_{OQ})

Two parameters, AGND and OFFSET, are used for adjustment of the V_{OQ} . The AGND is a 10 bit parameter for coarse adjustment of V_{OQ} . It has a resolution of approximately 0.014V and a range of $-100\%V_{DD}$ to $200\%V_{DD}$. The OFFSET is a 10 bit parameter with a resolution of approximately -0.005V. The OFFSET parameter is used for fine adjustment of the V_{OQ} , while the AGND parameter is used to set the range. The large adjustable range allows the MLX90277 to be used in an unipolar magnetic system without limiting the output voltage span. The formula below shows how the AGND and OFFSET parameters combine to set the V_{OQ} .

$$V_{OQ} = -0.75V + \left(\frac{14.25V}{1023} * AGND \right) + \left(-\frac{5.0V}{1023} * OFFSET \right) \Big|_{V_{DD}=5.00V}$$

This formula approximates the typical V_{OQ} of the MLX90277's individual sensors. The actual V_{OQ} formula varies slightly from IC to IC. Melexis calibrates the AGND setting during final test so that the V_{OQ} is approximately $50\%V_{DD}$ with OFFSET set to 512. This gives the V_{OQ} a range of $0\%V_{DD}$ to $100\%V_{DD}$ without adjusting the AGND value. The OFFSET parameter is often used to set the application's offset output transfer characteristic.

10.2 Thermal V_{OQ} Drift (DRIFT)

The Thermal V_{OQ} Drift is tuned using 4 bits. This parameter, DRIFT, is calibrated for each unit by Melexis during final test. The value is set to achieve a V_{OQ} accuracy below 10mV over a temperature span of 25°C to 150°C. This parameter is not used by the end customer.

10.3 Sensitivity, Rough Gain and Fine Gain

The Sensitivity of the MLX90277's individual sensors is controlled through parameters linked to dedicated internal amplification stages. The parameter Rough Gain (RG), or pre-amplifier, has 4 bits for adjustment of two stages. The two MSB affect the Differential Input Differential Output (DIDO) stage. The two LSB effect the Differential to Single output (DTS) stage. The gain of both the DIDO and DTS are multiplied to get the total RG. The table below shows typical values of the small signal amplifier gain vs. the parameter RG. The pre-amplifier is chopper stabilized and the refresh frequency is adapted automatically to the RG setting to match the chopper gain-bandwidth product.

Rough Gain (MSB LSB)	DIDO	DTS	Gain
00 (00 00)	16	1.0	16
01 (00 01)	16	1.5	24
02 (00 10)	16	2.33	37
03 (00 11)	16	4.0	64
04 (01 00)	39	1.0	39
05 (01 01)	39	1.5	59
06 (01 10)	39	2.33	91
07 (01 11)	39	4.0	156
08 (10 00)	82	1.0	82
09 (10 01)	82	1.5	123
10 (10 10)	82	2.33	191
11 (10 11)	82	4.0	328
12 (11 00)	205	1.0	205
13 (11 01)	205	1.5	308
14 (11 10)	205	2.33	477
15 (11 11)	205	4.0	820

Table 8: MLX90277 Rough Gain Small Signal Amplifier Gain

The MLX90277 sensors also have an additional stage, Fine Gain, for fine tuning the Sensitivity. The stage (parameter FG) follows the RG and provides a 10 bit adjustment. The small signal gain of the FG is within 1.0 and 2.5. The RG and FG parameters are adjusted in the application to calibrate the sensitivity (gain) and output slope transfer characteristic of the device. The function for the fine gain is given in the following equation:

$$\text{Fine Gain} = \frac{1}{1 - 0.6 * \frac{FG}{1023}}$$

Note. The one bit parameter INVERT is used to fix the “sign” of the sensitivity. A value of 0 makes the gain positive and the output voltage increases in response to a South magnetic field. A value of 1 makes the gain negative and the output voltage decrease in response to a South magnetic field. Refer to section 10.5, Sensitivity Polarity for more information on INVERT.

10.4 Sensitivity Range Selection

Each unit is characterized over temperature during final test to optimize its performance and accuracy. To achieve the best possible Sensitivity Temperature Compensation, TempCo., each unit is optimized for use within a specific Sensitivity range. This is represented in the ordering information by the option code. There are four available ranges, option codes 0, 1, 2 and 3. The option code corresponds with the two MSB of the RG parameter. Each device is tested to meet the TempCo specification in the Sensitivity range determined by the RG parameter (RG = 0...3, RG = 4...7, RG = 8...11 or RG = 12...15), regardless of the FG parameter. The Sensitivity range is selected independently for Sensor A and Sensor B. Melexis may limit the available combinations.

Option Code	Rough Gain	Sensitivity Range (mV/mT)	Typical Magnetic Field Range (mT, B _{MAX} - B _{MIN})
0	0-3 (00 xx)	2.6 < S < 15	333 < B < 800
1	4-7 (01 xx)	10 < S < 35	156 < B < 333
2	8-11 (10 xx)	18 < S < 90	62 < B < 156
3	12-15 (11 xx)	50 < S < 210	6 < B < 62

Table 9: Optimized Sensitivity Range

The next figures show the typical Sensitivity versus the FG and RG parameters. The gray areas are representative of the chip to chip dispersion (i.e.: for the same RG and FG parameters, the Sensitivity can vary from chip to chip). There is large overlap between the different ranges for use of one range for applications with large magnetic and/or mechanical dispersions. The Sensitivity graphs and tables can be used to select the right device type for the application. If one is unsure of the application’s magnetic design and the desired Sensitivity range Melexis recommends option code 2.

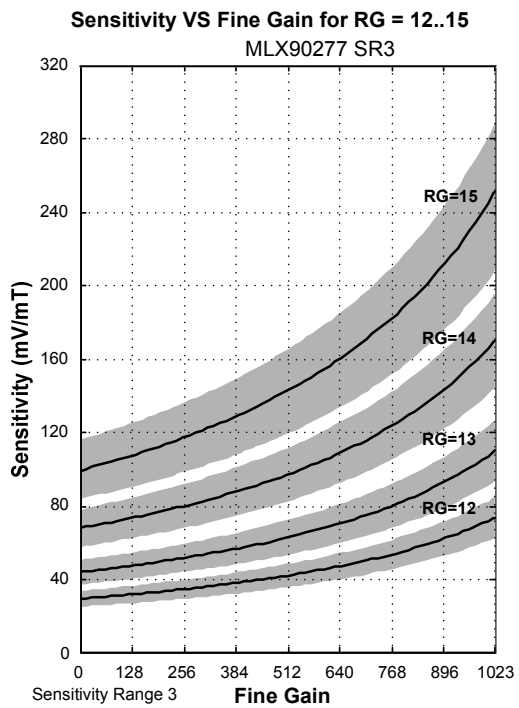
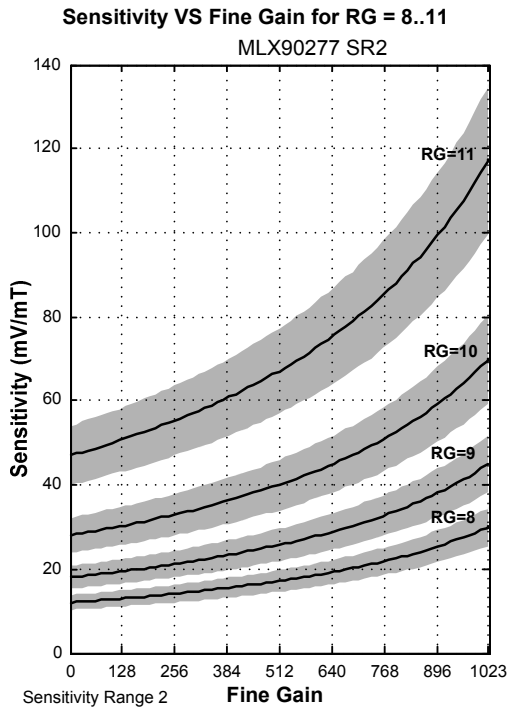
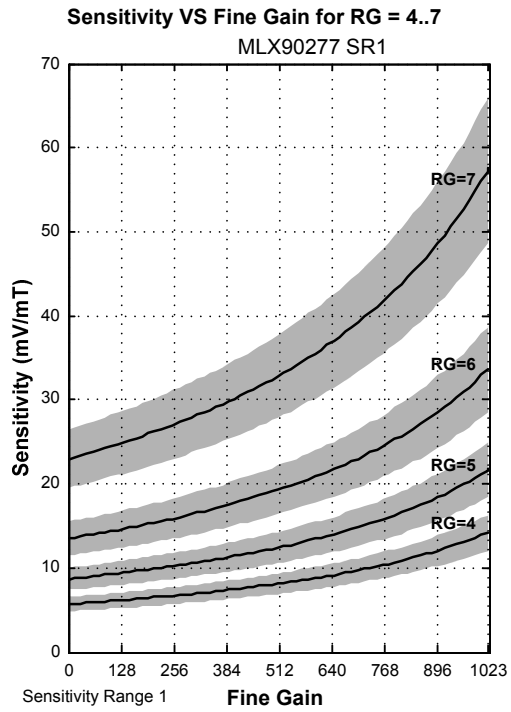
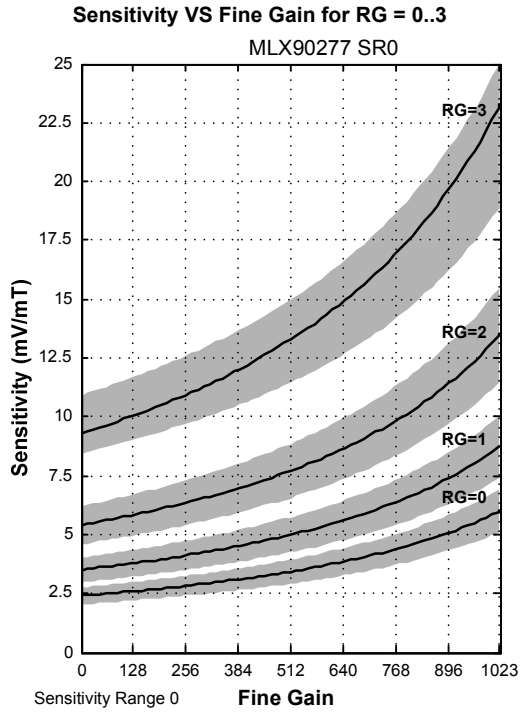

Figures 10.4-1...10.4-4 Sensitivity versus RG and FG

10.5 Sensitivity Polarity (INVERT)

The slope transfer characteristic defines the Sensitivity. The INVERT parameter changes the Sensitivity's polarity, or the slope's direction. This allows the device to accommodate the application requirements and the magnet's polarity. The slope is inverted in the first stage of the IC, at the Hall Plate. With INVERT set to 0, the output voltage increases as a South magnetic field is applied and decreases in the presence of a North magnetic field. An INVERT value of 1 causes the output voltage to increase in the presence of a North magnetic field and decrease in the presence of a South magnetic field. The magnetic field polarity is referenced to the field component perpendicular to the top-face of the MLX90277.

10.6 Clamping Levels (CLAMPLOW, CLAMPHIGH)

Two independent values, called the clamping levels, can limit the output voltage range or swing. The CLAMPLOW parameter adjusts the minimum output voltage level, ClampLo. The CLAMPHIGH sets the maximum output voltage level, ClampHi. Both parameters have 10 bits of adjustment with a resolution of approximately 0.005V. The formulas below give a close approximation of the output clamp voltage. The actual clamping level formulas vary slightly from chip to chip. If CLAMPLOW exceeds CLAMPHIGH the output voltage is fixed at the high clamp voltage level. The CLAMPHIGH and CLAMPLOW initial value of 768 for IC_A, set by Melexis, results in a fixed output voltage of approximately 76% V_{DD}. The CLAMPHIGH and CLAMPLOW initial value of 256 for IC_B, set by Melexis, results in a fixed output voltage of approximately 25% V_{DD}.

$$ClampLo = \frac{5.10V}{1023} * CLAMPLOW \Big|_{V_{DD}=5.00V}$$

$$ClampHi = \frac{5.10V}{1023} * CLAMPHIGH \Big|_{V_{DD}=5.00V}$$

At the point the output voltage switches between the linear operating region and the clamping region the output can deviate slightly. This is represented by the grey areas in the figure below. The limits for deviation in the Y axis are listed in Table 10. The deviation in the X axis is calculated from the application's transfer function. The Clamp Comparator Offset does not effect the output linearity or clamp voltage accuracy. During calibration it is recommended to set the clamp voltage outside of the transition region (0V to 5V).

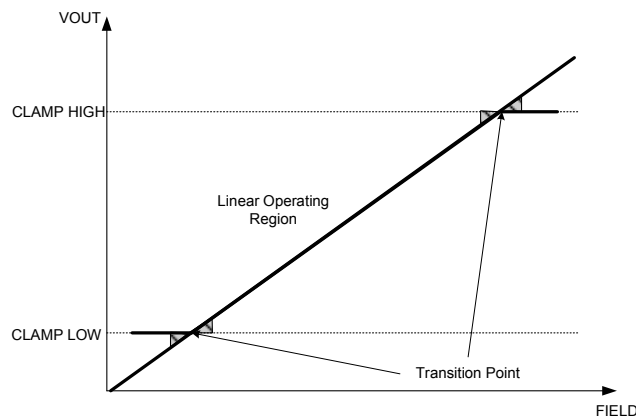

Figure 10.6 Output Voltage Clamping Deviation

DC operating parameters at V_{DD} = 5V (unless otherwise specified) and for T_A as specified by the temperature range (E or L).

Parameter	Symbol	Test Conditions	Min	Typical	Max	Units
Clamp Comparator Offset	CLAMP _{OFF}	-40°C to 85°C	- 0.7		+ 0.7	%V _{DD}

Table 10: Clamp Comparator Offset Specification

10.7 Filter (FILTER)

Each die of the MLX90277 includes two programmable low-pass filters located within the chopper amplifier stages. The two low-pass filters are controlled through a 4 bit parameter, FILTER. The FILTER value 0 corresponds to minimum filtering, maximum speed (impulse response time), and maximum output noise. The value 15 provides the maximum filtering, minimum speed, and minimum output noise. It is important to note the noise is also linked to the gain settings. The FILTER parameter needs to be adjusted to achieve optimal performance. The next table shows typical values of the cut-off frequency at -3 dB versus FILTER and RG parameters. FILTER values from 8 to 11 are not used. For most applications FILTER values 7 or 15 are recommended.

Cut-off frequency at -3 dB (Hz) – Typical

Filter	MLX90277 SR0 Rough Gain 0...3	MLX90277 SR1 Rough Gain 4...7	MLX90277 SR2 Rough Gain 8...11	MLX90277 SR3 Rough Gain 12...15
0	22900	14300	7000	3850
1	19500	11450	5550	2950
2	12300	10000	3000	2300
3	10400	6750	2100	1100
4	7450	3900	1500	850
5	5850	2900	1125	860
6	5700	2700	1350	715
7	5050	2550	1380	650
8	Not used			
9	Not used			
10	Not used			
11	Not used			
12	2200	840	565	250
13	1000	480	470	190
14	920	380	290	155
15	800	330	250	135

Table 11: Cut-off Frequency versus FILTER and RG Parameters

10.8 Sensitivity Temperature Compensation (TC, TCW, TC²)

The change in the device's Sensitivity versus temperature is defined as the Sensitivity Temperature Compensation, TempCo. In an application the slope output transfer characteristic is often affected by temperature. Fluctuations in temperature can cause variations in the air gap, mechanical alignment and magnetic field. The Sensitivity Temperature Compensation feature compensates for these effects.

Three parameters, TC, TCW, TC² are used for adjustment of the TempCo. The TCW is used to adjust the TempCo range, TC is for fine adjustment of the TempCo value, and TC² effects the TempCo linear response. To simplify use of these parameters Melexis stores a look up table within the EEPROM of each device. The look up table is optimized for each device by characterizing the unit over temperature at final test.

The value of TempCo is often determined by the magnet. In the application the TempCo is adjusted to compensate for the temperature coefficient of the magnet. To adjust the value the look up table is read from the device. The parameters are then calculated to match the desired value. The Melexis PTC hardware and software tools contain built in functions for programming the TempCo.

TempCo Range (ppm / °C)	Accuracy (ppm / °C)
0 to 500	± 100
500 to 1200	± 150
1200 to 2000	± 200

Table 12: TempCo Accuracy

Note: The budget error of the whole system, the compensation mismatch (system vs. IC) tolerance should be taken into consideration during the design. Table 11 is valid for Rough Gain within the specified option code. See section 10.4 for information on selecting the option code.

10.9 Diagnostic Output Level (FAULTLEV)

The MLX90277 sensors' EEPROM memory content is secured through a parity check. This self-diagnostic feature brings the output to a defined range in case of a parity error. The parameter, FAULTLEV, is used to define the parity error diagnostic state. With the FAULTLEV set to 0 a parity error event will result in an output diagnostic voltage low. With the FAULTLEV set to 1 a parity error event will result in an output diagnostic voltage high. To get rid of the output load influence the output diagnostic voltage level can be fixed to either Ground (to be used with pull-down load) or V_{DD} (to be used with pull-up load). Melexis PTC software and hardware tools have built in functions for calculating and programming the parity.

Note: The MLX90277 sensors' EEPROM is also redundant. Each parameter bit is written in three separate cells and a "majority voting" is applied to determine its status. A parity error is detected only if two out of the three cells unexpectedly change state. The bits available for the customer ID are not redundant.

10.10 The EEPROM, Parity and Melexis CRC

The memory cells of the EEPROM are arranged in a table of four columns and one hundred twenty eight rows. This configuration gives redundancy to the parameters stored in the EEPROM. Each parameter bit is written in three separate cells in an individual row. A majority voting applied to the three cells determines the logic status of the bit.

A parameter bit only toggles state in error if two out of three memory cells, within a row, unexpectedly change. If this happens the feature, PARITY, forces the output voltage to the FAULTLEV diagnostic level. This ensures the device does not operate with a critical memory fault.

The remaining memory cells are used for data storage. The status of these cells does not effect the device operation. For example the Customer ID, CUSTID, is stored in this area. Melexis stores the device ID information, TempCo look-up table and CRC bits in the extra cells. The CRC bits ensure the integrity of the Melexis data.

Note: To avoid parity and CRC errors, the entire contents of the EEPROM must be read before programming. Melexis PTC software and hardware tools have built in functions for reading the EEPROM and handling parity.

10.11 Output Amplifier Configuration (MODE)

The output buffer can be configured to accommodate capacitive loads and improve the saturation voltage (output swing). The two bit parameter, MODE, sets the current capacity of the output amplifier. Melexis sets this parameter to 1 at final test. This parameter is not used by the end customer.

10.12 Memory Lock (MEMLOCK)

The Memory Lock feature prevents the device from entering programming mode and from any changes to the EEPROM. The entire EEPROM is locked by setting the MEMLOCK parameter to 1. This should be the last parameter set in the application.

10.13 IC traceability

A unique ID number is programmed into the EEPROM of every IC. The ID number gives Melexis additional traceability to better service its customers. The ID number is composed of the lot number, wafer number and wafer coordinates (X and Y). Memory is also available for the customer to add a serial number of the product or any other data.

11 Performance Graphs

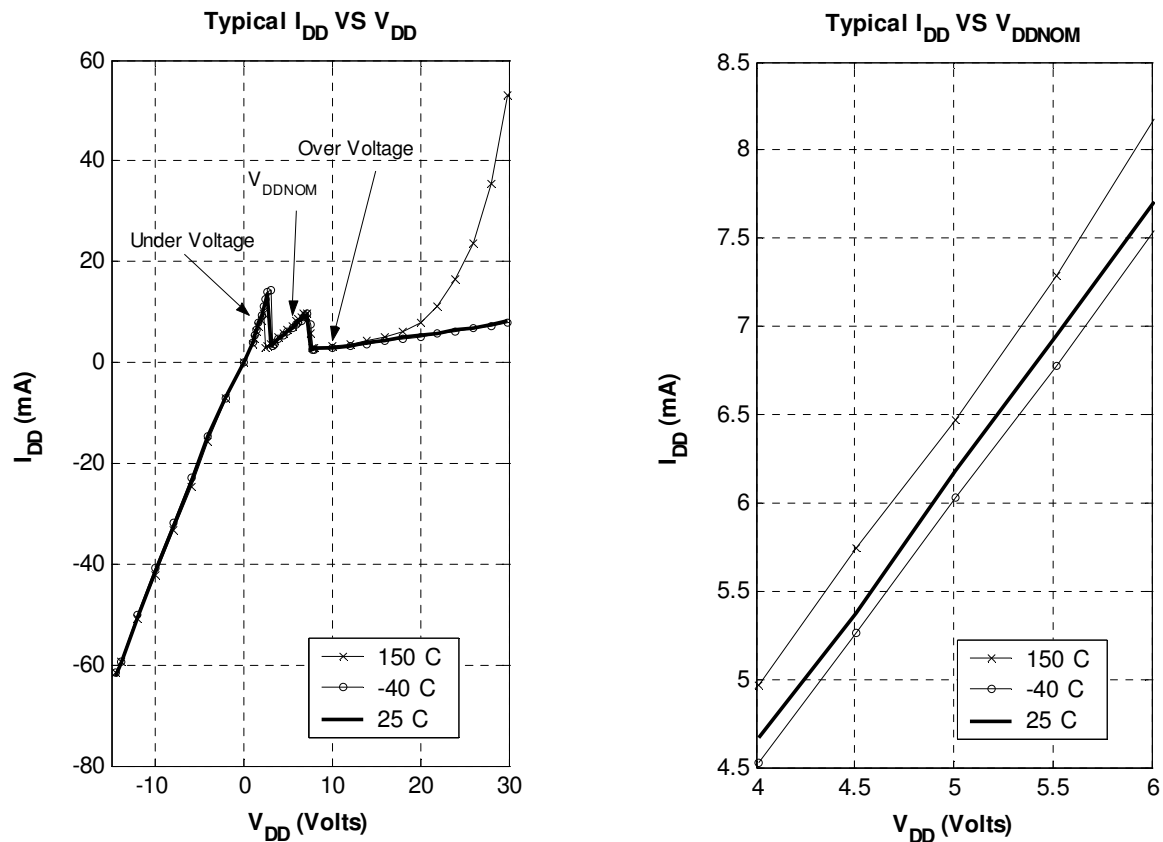

Figure 11-1...11-2 I_{DD} versus V_{DD}

12 Applications Information

12.1 Application Circuits

The TEST pins are not used in applications. For EMC protection it is recommended to connect the TEST pins to Ground as close as possible to the device pins. The values for capacitors, C11, C12, C21 and C22, can be adjusted to satisfy ESD and EMC requirements according to the environment. Ceramic capacitors are recommended for use in the application. However for stable operation, C12 and C21 should each not be higher than 150nF. If higher capacitors (due to special ESD or EMC requirements) or special circuit configurations are requested, please contact Melexis.

The MLX90277 can operate with a high impedance load; a load resistor is not required.

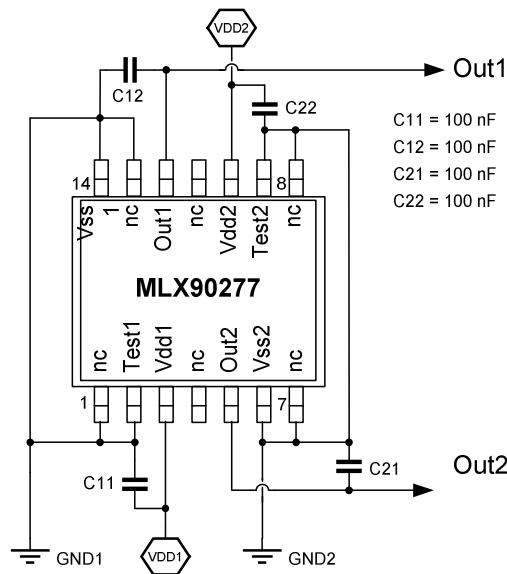

Figures 12.1-1...12.1-2 Application Circuits

A voltage of 9V is required on V_{DD} for programming. All additional components connected to V_{DD} must be able to withstand the voltage.

The MLX90277 is designed for operation with a stable 5V supply. If fast voltage transients occur additional filtering may be required.

12.2 Programming the Sensor

To program the individual MLX90277 sensors, connection to V_{DD} , GND, and V_{OUT} is required. The device is placed into program mode by increasing the supply voltage to the V_{DD} program level. In program mode data is clocked into the device through the output pin using the Melexis tri-level PTC protocol. The clock and data are integrated into one serial data stream, eliminating the need for a dedicated clock signal. The data is clocked at the leading edge of each bit.

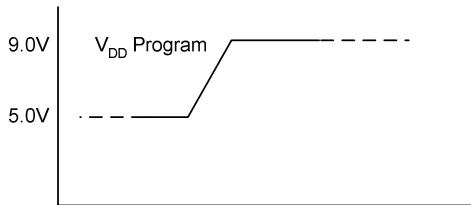

Figure 12.2-1 V_{DD} Programming Level

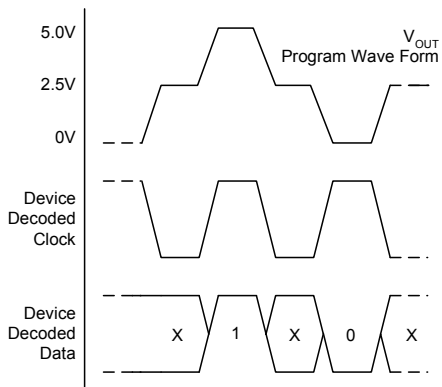

Figure 12.2-2 Tri-Level PTC

Note: External capacitors and resistors will effect the rise and fall times for the programming waveforms. Program pulse timings may require adjustment for the application. The device can not be programmed if MEMLOCK equals 1.

The EEPROM contents can be read from the device. This procedure, known as a read back, is done by sending a read command and then measuring the supply current. To successfully read the EEPROM it must be possible to measure the supply current to the device. The Melexis PTC hardware and software tools contain built in functions for reading the EEPROM.

The MLX90277 sensors can be programmed by using the PTC-04 programmer and the dedicated software tools. The timing and voltage levels are controlled through the programming hardware and software. Further details can be found in the MLX90277 software documentation.

12.3 Calibration Procedure

The programmable features of the device allow it to be calibrated within the application. This section gives general information for a two point calibration procedure. The two point calibration is the most common, however, it is possible to adapt other procedures.

- 1.) The first step in the calibration procedure is to initialize the device. This is done by establishing communication and reading the contents of the EEPROM.
- 2.) The second step is to set the TempCo and FILTER settings.
- 3.) Step three is the evaluation of position one. During this step the output voltage is measured with initial values for RG, FG and OFFSET.
- 4.) Step four is the evaluation of position two. During this step, the output voltage is measured with the same values from step 3. From the measurements it is possible to calculate the slope and offset error. Next the output slope transfer characteristic versus FG and RG is interpolated. With this information the initial settings are adjusted and the output voltage is measured again.
- 5.) Step five is the final check and adjustment. At this stage small corrections are made to the OFFSET and FG parameters. Next, the output clamping parameters, CLAMPHIGH and CLAMPLOW, are determined.
- 6.) The sixth step is the program phase. Now that all the parameters are determined and the application requirements are satisfied, the settings are programmed into the EEPROM.
- 7.) The final step, seven, is the lock and verify step. Here the customer can perform any number of additional measurements and verify the EEPROM contents. After this is completed the MEMLOCK is set and the EEPROM is locked, preventing any further programming.

Note: EEPROM verification is done by reading the contents of the EEPROM and comparing it to the data written. It is possible to read the EEPROM contents regardless of the status of MEMLOCK.

The Melexis PTC software tools contain built in functions and procedures for calibrating the MLX90277. Please refer to the software documentation for more information on how to use the calibration tools.

The outputs of the MLX90277 are ratiometric. To avoid calibration errors from fluctuations in the supply voltage, the output voltage should be measured as a percentage of the supply voltage.

13 Standard information regarding manufacturability of Melexis products with different soldering processes

Our products are classified and qualified regarding soldering technology, solderability and moisture sensitivity level according to following test methods:

Reflow Soldering SMD's (Surface Mount Develops)

IPC/JEDEC J-STD-020
Moisture/Reflow Sensitivity Classification for Nonhermetic Solid State Surface Mount Devices
(classification reflow profiles according to table 5-2)
EIA/JEDEC JESD22-A113
Preconditioning of Nonhermetic Surface Mount Devices Prior to Reliability Testing
(reflow profiles according to table 2)

Wave Soldering SMD's (Surface Mount Develops) and THD's (Through Hole Develops)

EN60749-20
Resistance of plastic- encapsulated SMD's to combined effect of moisture and soldering heat
EIA/JEDEC JESD22-B106 and EN60749-15
Resistance to soldering temperature for through-hole mounted devices

Iron Soldering THD's (Through Hole Develops)

EN60749-15
Resistance to soldering temperature for through-hole mounted devices

Solderability SMD's (Surface Mount Develops) and THD's (Through Hole Develops)

EIA/JEDEC JESD22-B102 and EN60749-21
Solderability

For all soldering technologies deviating from above mentioned standard conditions (regarding peak temperature, temperature gradient, temperature profile etc) additional classification and qualification tests have to be agreed upon with Melexis.

The application of Wave Soldering for SMD's is allowed only after consulting Melexis regarding assurance of adhesive strength between device and board.

Melexis is contributing to global environmental conservation by promoting **lead free** solutions. For more information on qualifications of **RoHS** compliant products (RoHS = European directive on the Restriction Of the use of certain Hazardous Substances) please visit the quality page on our website:
<http://www.melexis.com/quality.asp>

14 ESD Precautions

Electronic semiconductor products are sensitive to Electro Static Discharge (ESD).
Always observe Electro Static Discharge control procedures whenever handling semiconductor products.

15 Package Information

The TSSOP14 package is lead-free and is released for MSL3/260°C.

15.1 Package Dimensions

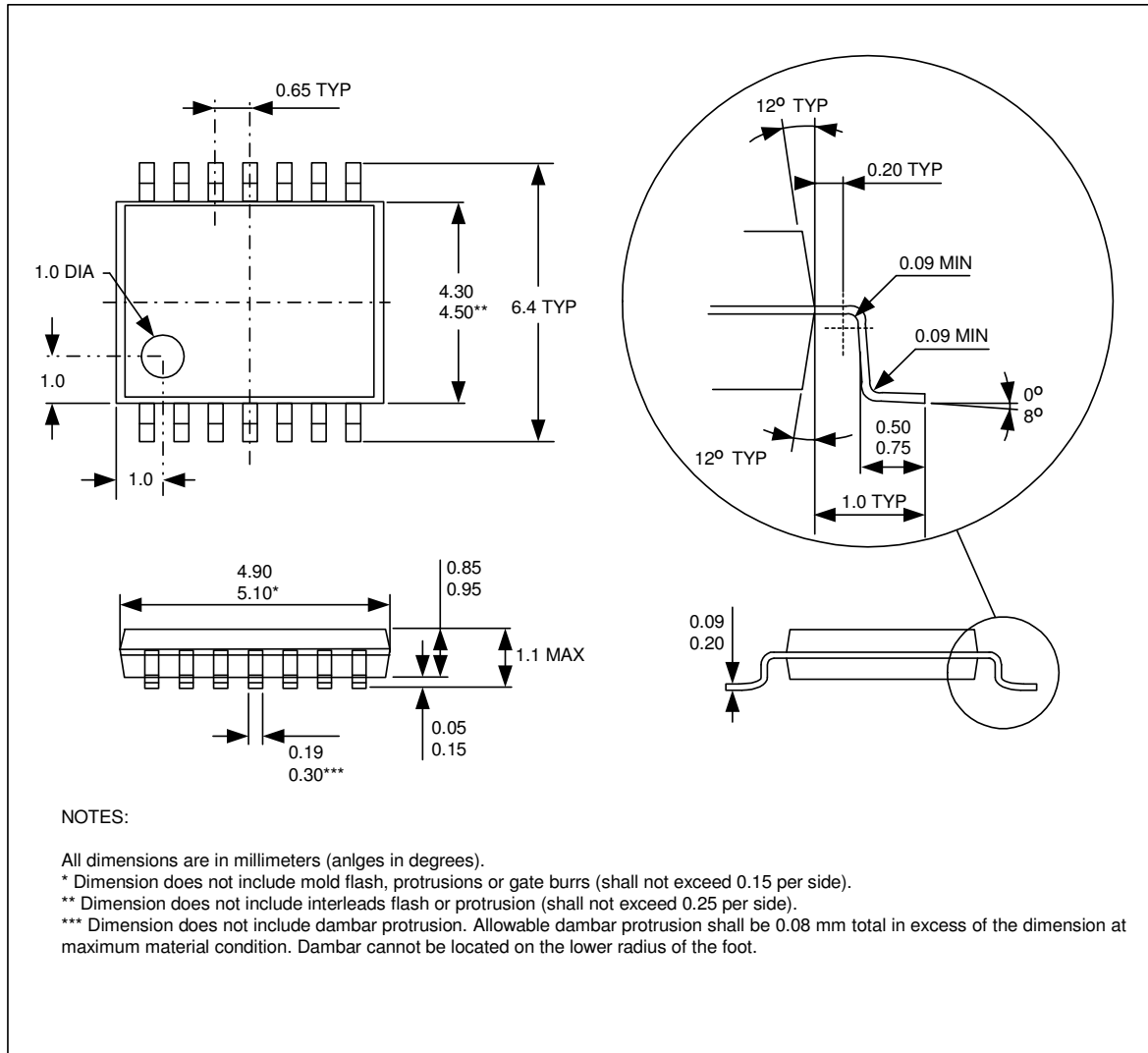

15.2 Pin-out and Marking

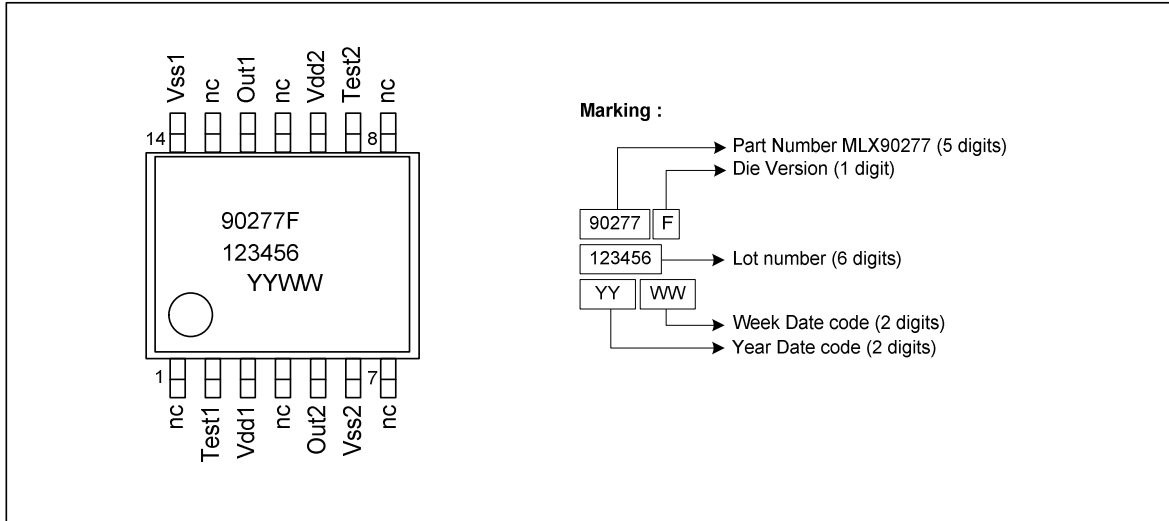

15.3 Hall Plate Positioning

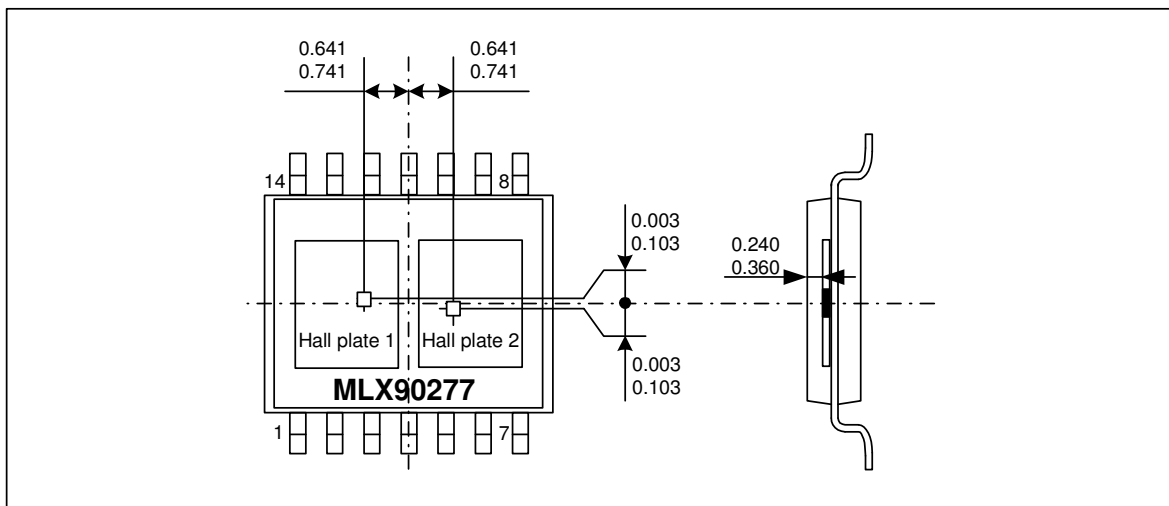

16 Disclaimer

Devices sold by Melexis are covered by the warranty and patent indemnification provisions appearing in its Term of Sale. Melexis makes no warranty, express, statutory, implied, or by description regarding the information set forth herein or regarding the freedom of the described devices from patent infringement. Melexis reserves the right to change specifications and prices at any time and without notice. Therefore, prior to designing this product into a system, it is necessary to check with Melexis for current information. This product is intended for use in normal commercial applications. Applications requiring extended temperature range, unusual environmental requirements, or high reliability applications, such as military, medical life-support or life-sustaining equipment are specifically not recommended without additional processing by Melexis for each application.

The information furnished by Melexis is believed to be correct and accurate. However, Melexis shall not be liable to recipient or any third party for any damages, including but not limited to personal injury, property damage, loss of profits, loss of use, interrupt of business or indirect, special incidental or consequential damages, of any kind, in connection with or arising out of the furnishing, performance or use of the technical data herein. No obligation or liability to recipient or any third party shall arise or flow out of Melexis' rendering of technical or other services.

© 2006 Melexis NV. All rights reserved.

For the latest version of this document, go to our website at
www.melexis.com

Or for additional information contact Melexis Direct:

Europe, Africa, Asia:	America:
Phone: +32 1367 0495	Phone: +1 603 223 2362
E-mail: sales_europe@melexis.com	E-mail: sales_usa@melexis.com

ISO/TS 16949 and ISO14001 Certified